

VALID BECAUSE DIFFERENCE IS WITHIN 5 MM

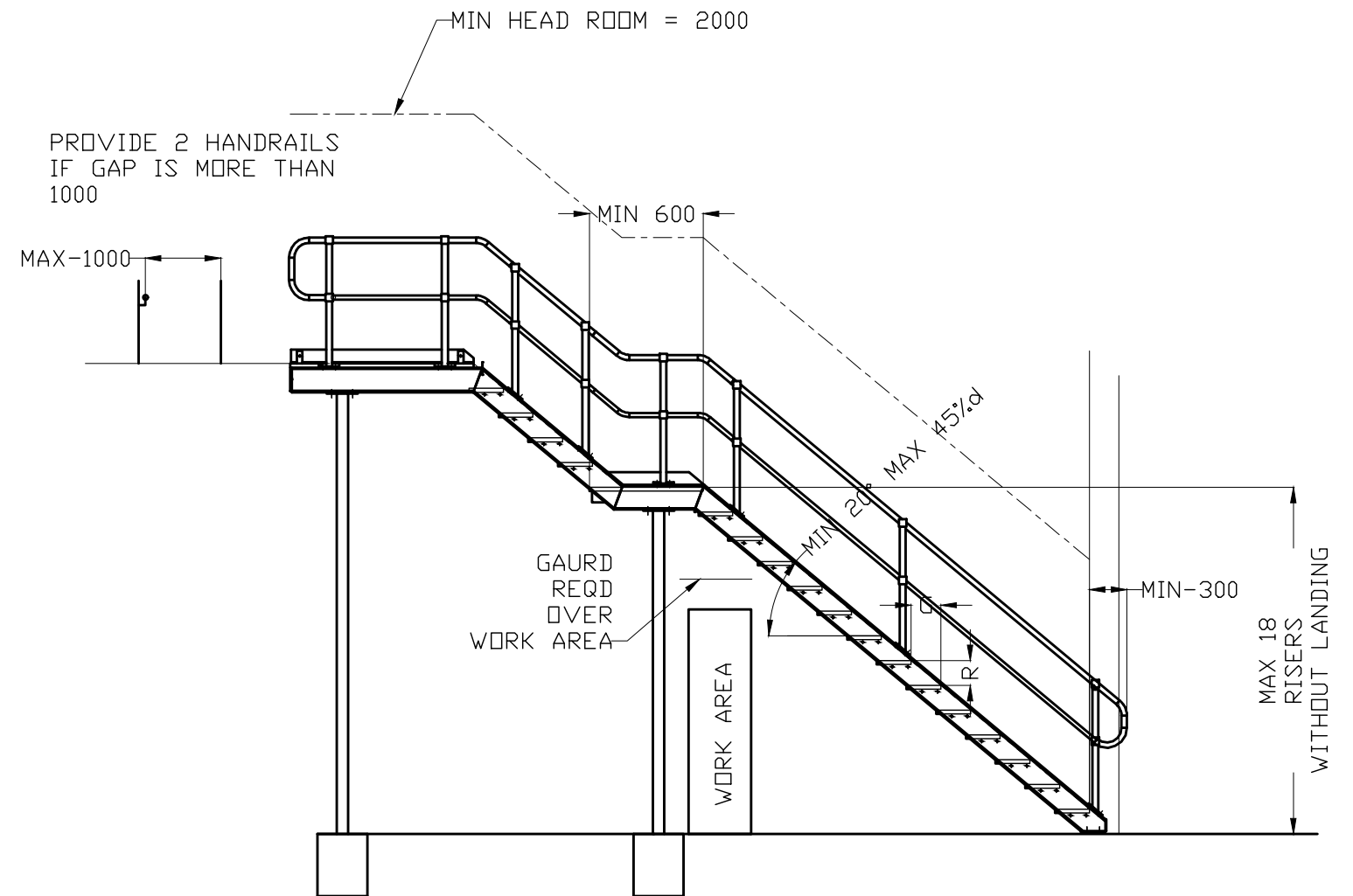
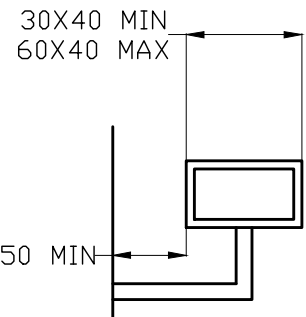
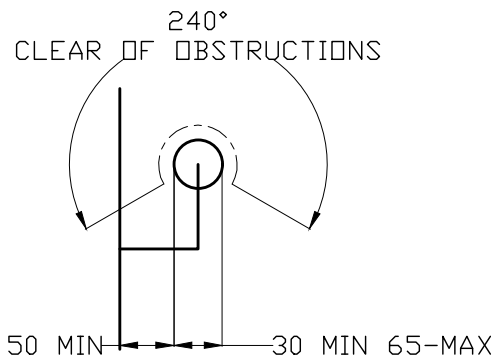
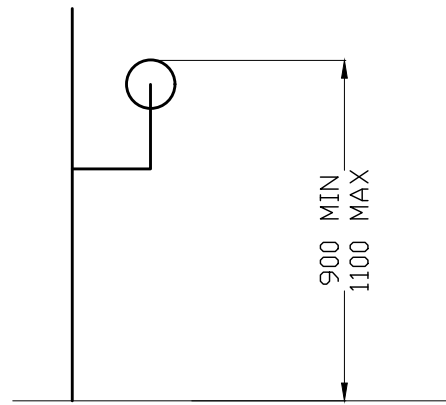
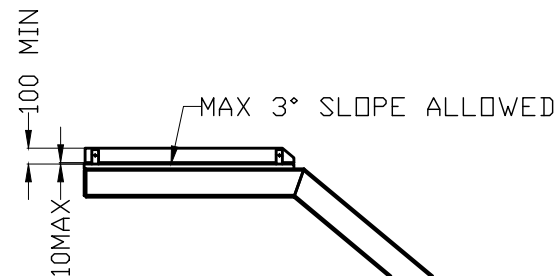

G- MIN = 215 - MAX = 355  
 R- MIN = 130 - MAX = 225  
 ALSO  
 $540 \leq (2R+G) \leq 700$   
 R AND G SHOULD BE UNIFORM WITHIN 5 MM TOLERANCE

**A - A**

Notes:	Rev	By	Date	Description	AS1657	TEK1 PTY LTD			
	A		//	ISSUED FOR APPROVAL					
					www.tek1.com.au	Drawn By:	TEK1		
						Checked By:			
						Approved By:			
					Scale:	Project No:	Drawing No:	Size:	Rev
					1:50		info@tek1.com.au	A3	A